

DIY BUILD INSTRUCTIONS – PLITKA BRUT RUT (PASSIVE CABLE ROUTER)

First off, thank you for your purchase of the PLITKA BRUT RUT Front Panel. If you are a DIY Synth novice, you have selected a great module to strengthen your skills. If you are a veteran [or, as we like to say at Tsyklon Labs - “Hero of Synthesizer DIY”], then this kit will be super fun and you will likely have it assembled in mere minutes.

First, let’s make sure that you have everything on hand before we heat up the iron. The tools you will need are as follows:

- Soldering Iron and Solder
- Knurled Nut Tool [Xicon 382-0006] or Small Pliers for tightening 3.5mm knurled nuts
- Wire Strippers
- Wire of your choosing - Solid 24awg or 22awg works well

You will need the following parts to finish your build:

Qty	Part Description	PCB Component ID	Part Number	Vendor
4	3.5mm Inline Jacks (Thonkiconn Style)	IN_CV, IN_GATE, OUT_CV, OUT_GATE	PJ30IM-I2	Various
4	3.5mm Knurled Nuts	IN_CV, IN_GATE, OUT_CV, OUT_GATE	3.5mm Knurled Nuts	Various

These jacks are available from Thonk, Modular Addict, Synthrotek, and Erthenvar. Most vendors sell the nuts with the jacks, but check to be certain you have all of the parts that you will need.

1) First, take a look at the Front Panel and check that all of the printing is intact. If your panel says “DIOD OR” instead of “BRUT RUT” - DO NOT PANIC! Just flip the panel over. All of the PLITKA v2 panels are two sided and are used for different modules that have similar hole patterns:



2) Install the jacks into the Front Panel and fix them in place with the jack nuts. This will keep everything together while you solder the pins together. Tighten the nuts until they are snug - no need to go crazy tight on them. If you are using pliers instead of a Knurled Nut Tool, be careful not to scratch the front panel. Also, you want to position the jacks so that ground pins are close to each other - this will make it easy to connect them together:



3) Solder the ground pins together for each pair of jacks [and you can connect all four together as well]. Then, take two more pieces of wire and use them to connect each pair of the signal pins together. IN_CV to OUT_CV and IN_GATE to OUT_GATE.

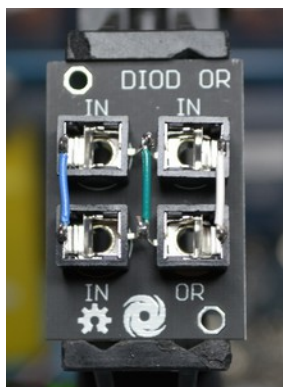

4) That's it! Job well done, Udarnik! Enjoy the fruit of your labors - get patching!

Document Published: 27 March 2017

INTERPRETING COMPONENT DESIGNATIONS FOR TSYKLON LABS MODULES

As much as possible, we have tried to be very consistent with how our components are labeled on our Printed Circuit Boards [PCBs]. Aside from being consistent component to component, PCB to PCB, and module to module within our own products – we have also done as much as possible to be consistent with standard naming conventions used by other module designers. The table below lists component types and their designations. We will use 000 in place of the identification numbers normally used so that you can see what the component number will look like. Most prefixes are one to two characters long, but can occasionally be three characters.

COMPONENT ID	EXAMPLE	COMPONENT TYPE
R	R000	Resistor
C	C000	Capacitor
PB	PB_RESET	Push Button
SW	SW_INVERT	Switch [Toggle]
VR	VR000	Variable Resistor [Potentiometer or Trimmer]
LED	LED000	Light Emitting Diode
D	D000	Diode
Q	Q000	Transistor [BJT, FET, or MOSFET]
IC	IC000	Integrated Circuit
MHDR	MHDR_NBL	Male Header
FHDR	FHDR_NBL	Female Header
FB	FB000	Ferrite Bead
XTAL	CLK_XTAL	Quartz Crystal
REG	IOVREG	Voltage Regulator
PF	PF000	Resettable Poly Fuse
POWER	POWER	Power Header [2x5 or 2x8]
L	L000	Inductor

With regard to the numeric part of the component designation – 100 series numbers are for the PCB closest to the Front Panel. 200 series numbers are the next PCB behind the first, 300 series belong to the PCB behind that. While it would make sense that 400 series component numbers are for the next PCB behind that, in some cases those components are on the PCB for the expander module. Make sense? Great, go forth and build!

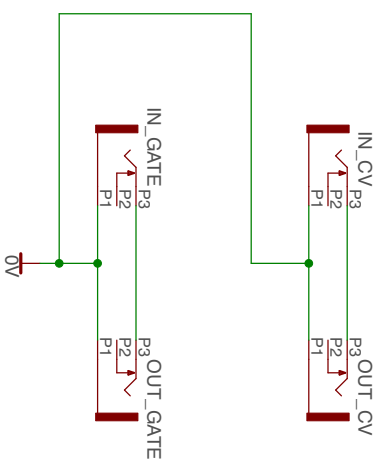

TSYKLON LABS

DOCS: <http://tsyklon.com/piltika/>
SKU : Brüt Rüt v2.1

DATE: 12 MARCH 2017

Sheet: 1/1